



ONE DUSUN
residences



“The whole world is one family.”
“天下一家”



SUN YAT SEN
孙中山

BALESTIER - HISTORY, HERITAGE, CHARM

RICH IN HISTORY

Think of Balestier and you are likely to think of the endless rows of architecturally conserved shophouses, decorative lighting and building material shops; and the myriad of coffee shops and stalls selling local delights such as bak kut teh, chicken rice, local kuehs, tau sar piah and durians.

With links to USA, Europe, as well as China, Balestier is rich in history and home to the Sun Yat Sen Nanyang Memorial Hall (formerly known as the Sun Yet Sen Villa). This double storey, colonial villa is located off Balestier Road, and hosted the father of modern China, Sun Yat Sen who visited Singapore eight times between 1900 and 1911. The villa later became the Southeast Asian headquarters for Sun's revolutionary movement.

Gazetted a National Monument on 28 October 1994, the villa symbolises the contributions of overseas Chinese to the revolutionary movement in China, as well as the inspiration of Sun Yat-sen's nationalist ideals on the people of Singapore.

Balestier Road was named after Joseph Balestier, the first American Consul right here in Singapore,

Balestier area was first developed as a 1,000 acre sugarcane plantation in 1834 and was named Balestier Plain. Joseph was married to Maria Revere Balestier, daughter of Paul Revere who was the maker of the famous Liberty Bell in Philadelphia. As a gift from Maria to St. Andrew's Cathedral in 1843, Singapore became the only place outside the United States that has a Revere bell, which is now part of the collection at the National Museum of Singapore.

PRESERVING ITS HERITAGE AND CHARM

A trip through this heritage-rich district with its conservation shophouses from more than 100 years ago, along with the development of new buildings sprouting up around the area, speaks of its significant past and vibrant present.

Because of its strong heritage value, Balestier has been designated as one of Singapore's Identity Nodes in URA's Identity Plan in 2002 with plans for URA to improve the walkways and landscaping in the area.

HERITAGE TRAIL



SUGARCANE PLANTATION

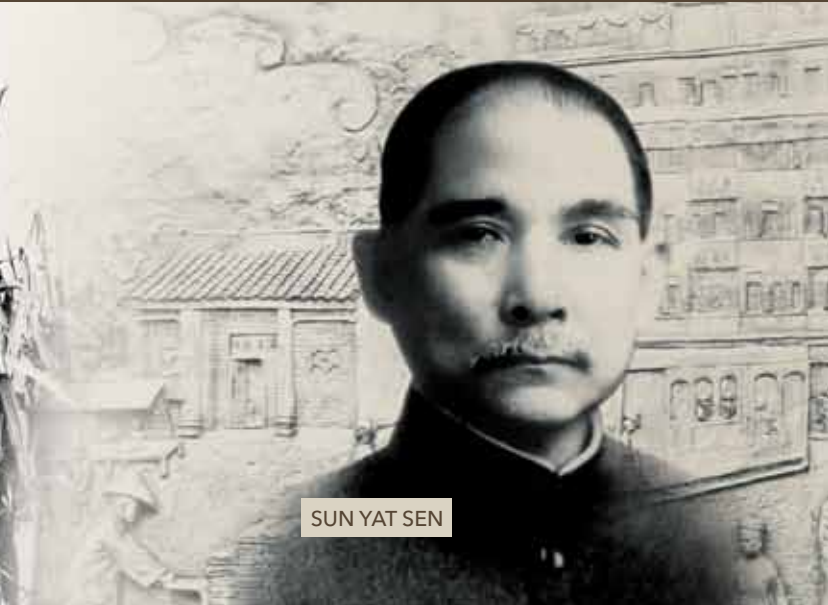

SUN YAT SEN

壹豪苑 — 伫立在历史的氛围，散发着文化的魅力

风情洋溢的 马里士他

座落于溢满历史氛围的 马里士他，为 壹豪苑增添了浓浓的文化风采。周围环绕的是充满异国情调的保留建筑、闻名遐迩的地道美食，如著名的肉骨茶、鸡饭、豆沙饼、飘香的榴莲。而鼎鼎有名的孙中山纪念馆也座落于 马里士他，见证着孙中山先生在新加坡留下的珍贵历史。如此琳琅满目、多姿多彩的环境令 马里士他在国人的心目中也别有一番意义与亲切感。

马里士他以首位居住于新加坡的美国领事 Joseph Balestier 的姓氏命名。早在百多年前 马里士他还是 一座 1000 多英亩，名为 Balestier Plain 的甘蔗庄园。经过百年的历史变迁，市区重建局于 2002 年将它规划为最具新加坡象征意义的历史文化区域。周围超过百年的建筑、走道及四周环境都经过一番严谨的装修重建，加上新式建筑的兴建，令今日的 马里士他融入新旧文化的相互辉映，更加风情万种。

壹豪苑 威风鼎立

拥有 29 层楼高的 壹豪苑在 马里士他中心傲然鼎立。它集合了 154 个住宅单位，全座落于 7 楼或以上，住户们可享受登高远望、一目千里的心情。

一应俱全的休闲设施也聚集于 7 楼，包括宽敞的泳池、迎向阳光的甲板、玻璃帷幕的健身房、活动及游戏露台、BBQ 亭台、室内宴会厅、娱乐与休闲庭院、儿童游乐场等。您可以畅快使用任何设施，让生活随时充满动感。

全座大楼共有 7 间分别设在 29、30 楼的顶层复式楼，远处可观望青葱翠绿的 Chancery Hill，而灯火辉煌的乌节路夜景也近在眼帘。四通八达的交通包括环岛快速公路、中央快速公路以及南北地铁线，来往全岛易如反掌。邻近设施如中山公园、Shaw Plaza、Velocity 及 Square 2 也为紧张的生活增添休闲乐趣。

自由空间、苏豪风格

现代化的苏豪风格(SOHO)也在 壹豪苑展示与众不同的生活品味。它以飞跃传统的建筑风格吸引了年轻一族的垂青。壹豪苑的所有单位均具备高天花板的规格。住户可以发挥创意，尽量利用横竖比例的宽敞空间，双管齐下展现舒适与实用的住宅空间，以阁楼作为休息室、垂直楼层为客厅或工作间。SOHO 创意的自由空间更是现代人梦寐以求的黄金格局。

为了让您获得随时拥有的住宅享受，壹豪苑更计划了两层购物与消遣楼面。共有 75 个零售单位，集合了饮食与时尚店铺。无论您要即时享受一杯香浓咖啡、来一客热餐点，临时需要一套时尚服饰，加些精美饰物，或要到 SPA 放松一天的疲惫，这一切均在您举手可得之处。

医疗中心、都市新贵

壹豪苑另一特色是靠近多间知名的医疗中心。身为亚太医疗枢纽的新加坡，自 2009 年起，每年平均吸引超过 660,000 名国外人士前来接受医疗服务，2012 年的目标更要超过百万。附近著名的 Mount Elizabeth Novena 医院、康生医疗中心(Thomson Medical Centre)、John Hopkins 新加坡国际医疗中心等均是外国人士最信赖的医疗中心。医疗设备的集中不仅吸引许多需要停留等待医疗报告的人士暂住此地，更招聘了许多国外专业人士到此任职，而他们的住所更以 马里士他为最受欢迎的地区。壹豪苑即将成为外国人士争相租用或购买的热门佳选。因此作为投资，壹豪苑将是无可匹敌的选择。

豪门之阁，引领时尚

壹豪苑屹立在历史的长廊，是一颗独占鳌头、孕育着璀璨的耀眼明珠。它配合时尚、保留文明，掌握了现代人对家的实际要求，呈现了舒适居住、明快生活的节奏韵律，予您放眼四周、感怀所有的亲和。

PRESERVING HERITAGE





Artist's Impression

ODR boasts 154 residential units and stands at 29 storeys high. All apartments are located at or above the 7th floor, while the infinity pool, facilities deck and activity pavillions sit on the 7th floor, enabling the entire development to tower above its neighbours.

Only for the discerning few, this luxury residence opens up to 7 penthouses occupying both the 28th and 29th floors, offering views of the Orchard Road skyline and lush greenery of the Chancery Hill vicinity.

Served by the nearby PIE, CTE and the North-South MRT line, getting to other parts of Singapore has never been easier. And with the many shopping and entertainment centres at Zhong Shan Park, Shaw Plaza, Velocity and Square2 located within walking distance of ODR, shopping and dining will never be more convenient.



Lifestyle
Shopping
Entertainment
Education





ONE DUSUN
residences

- | | | | | | | | | |
|----------------------|-----------------------|---------------------|--------------|--------------------------|-----------------|------------------------|-------------------------------|---------------------|
| 6 mins drive | 10 mins walk | 8 mins walk | 4 mins drive | 4 mins drive | 7 mins walk | 10 mins walk | 8 mins drive | 8 mins drive |
| MacRitchie Reservoir | Toa Payoh MRT Station | Toa Payoh Town Park | CHIJ School | SJI International School | Zhong Shan Park | Tan Tock Seng Hospital | Novena MRT Station & Velocity | Orchard MRT Station |
| 4 mins drive | 4 mins drive | 4 mins drive | 4 mins drive | 4 mins drive | 30 Sec drive | 2 mins drive | 3 mins drive | 8 mins drive |
| 10 mins walk | Toa Payoh HDB Hub | 13 mins walk | 12 mins walk | 12 mins walk | 4 mins walk | 8 mins walk | 10 mins walk | 3 Stops |

Medical Hub



MINUTES FROM WORLD CLASS MEDICAL HUB

ODR is within close proximity to Singapore's premier medical hub at Novena and nearby medical facilities. There are 4 hospitals, 2 specialist centres, 2 medical research and education institutions within walking distance of ODR:

- Mount Elizabeth Novena Hospital
- Tan Tock Seng Hospital
- Thomson Medical Centre
- Renci Hospital
- Novena Medical Suites,
- Novena Medical Centre
- Lee Kong Chian School of Medicine
(Collaboration with The Imperial College London)
- John Hopkins Singapore

International Medical Centre. Also, 4 internationally-renowned hotels serve the medical tourism hub:

- Ibis Hotel
- Oasis Hotel,
- Ramada Hotel (soon to be completed)
- Days Hotel (soon to be completed)

According to the EDB's record, Singapore's world-class healthcare facilities drew more than 660,000 foreign patients in 2009. This demand is likely to grow, given better health awareness, longer lifespans and improving economic circumstances across the region. Singapore's target is to grow the number of foreign patients to 1 million by the year 2012. Many analysts believe that the healthcare business is a recession proof business, which will enjoy sustainable healthy growth over the next few years.

The Novena medical hub leverages on all three: the public sector, research institutes and global industry partners to provide a complete spectrum of clinical services from basic health screening to sports medicine to surgery. Its success will create business and employment opportunities and this in turn will create demand for residential and commercial space in the vicinity.



ODR will benefit from the success of the Novena medical microcosm. Potential homeowners who work in the Novena medical hub will be attracted by ODR's close proximity to their place of work. Potential investors will be drawn by the strong rental demand for accommodation from the professionals, managers and staff working in this healthcare, medical research, medical tourism and hospitality hub. Small business owners supporting the Novena medical cluster will also find our SOHO (Small office /Home office) apartment concept an attractive proposition as they will be able to maximize their real estate investment for the twin purposes of living and working.



Artist's Impression

SHOPPES AT ODR

Designed with your comfort and convenience in mind, residents will be living above a cosy shopping enclave consisting of 2 storeys of 76 exciting retail stores.

A collection of F&B outlets, shopping and lifestyle services will enable residents to get their daily necessities, spa treatment, morning cup of coffee and toast right at their doorstep.





SOHO

Loft construction to conformed based on BCA guidelines.



SPACE CREATION TO LIVE, WORK AND PLAY.

Perfect for the urbanite, SOHO (Small Office/Home Office)-style living is about reinventing the boundaries of traditional spaces and opening up residents to a whole new lifestyle. Every ODR apartment will come with high ceilings, enabling residents to find creative ways to optimise horizontal and vertical spaces. Loft living will enable residents to make use of vertical "void" spaces to sleep, rest and relax, while leaving horizontal floor level space for work and play. SOHO compact living style allows residents to create more time for family life and bonding by reducing travel time. SOHO residents will further save on travel cost and avoid escalating rental cost.

SITE PLAN



A) Swimming Pool

B) Bubble Pool

C) Jacuzzi Pool

D) Pool Deck

E) Meditation Deck

F) Gymnasium

G) Poolside Dining Area

H) Children Playground

I) Reading Lounge Area

J) Private Dining Area

K) Barbeque Dining Area

L) Barbeque Area

M) Landscape Garden

N) Landscape Garden

O) 6m High Water Feature

P) Main Entrance

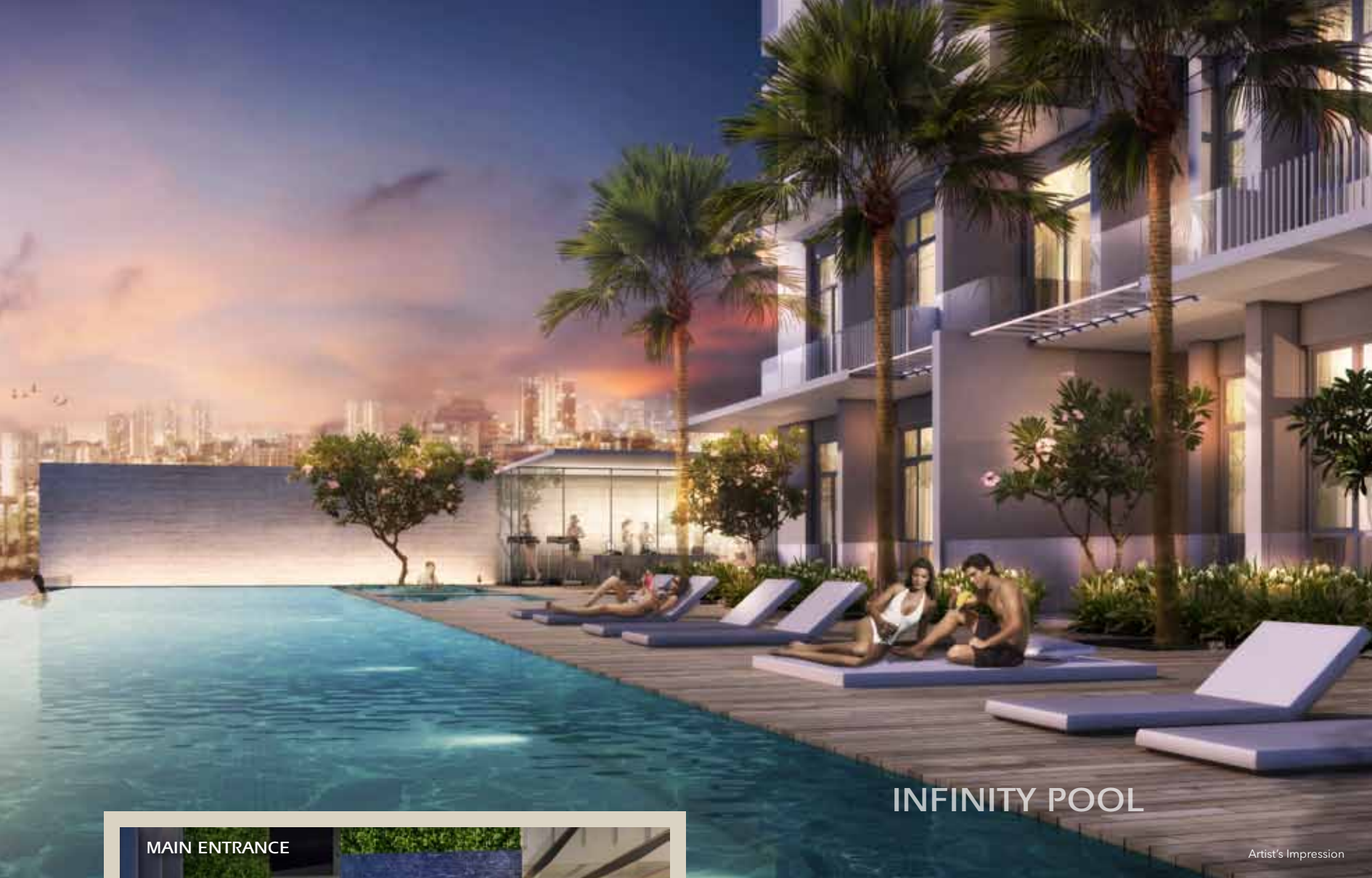

INFINITY POOL

Artist's Impression



MAIN ENTRANCE

6m High Water Feature

Artist's Impression



LIFESTYLE PAVILION

Artist's Impression

INFINITY POOL AND BEYOND

On a lazy Sunday morning, dive into the cool waters of the swimming pool or bask in the rays of the swimming pool sun deck on the 7th floor. Access this infinity pool and surround yourself with the panoramic views before you. Or work out a sweat and feel your heart race as you hit the glass-encased gym located next to the swimming pool. As you take in the beautiful view, working out at the gym has never been more fulfilling. For those who prefer quiet exercise or meditation in the early morning, you can perform your yoga exercises on the wellness platform.

Savour your first meal of the day on the laid-back charm of the Breakfast Deck. It's the best way to start the day with a hearty meal and great surroundings.

In addition, three lifestyle pavilions await you. A BBQ pavilion, a private dining pavilion, an entertainment/living/games pavilion awaits you. You can relish the intimacy of private dining with close friends at the private dining pavilion or hang out with your buddies at the entertainment pavilion on a Friday night.

A cosy playground offers endless fun for the young ones. Play with your kids and build lasting memories of joy and excitement with them.



2-BEDROOM

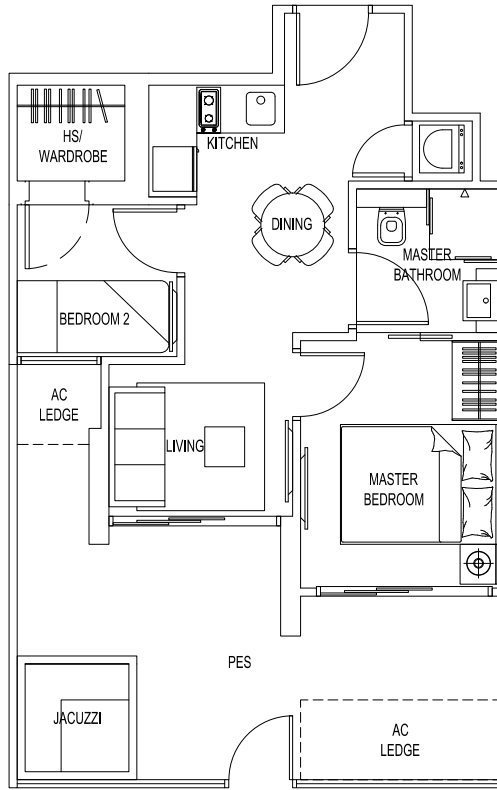

A1-G

AREA: 56.0 sqm

UNIT: #07-07

7TH STOREY

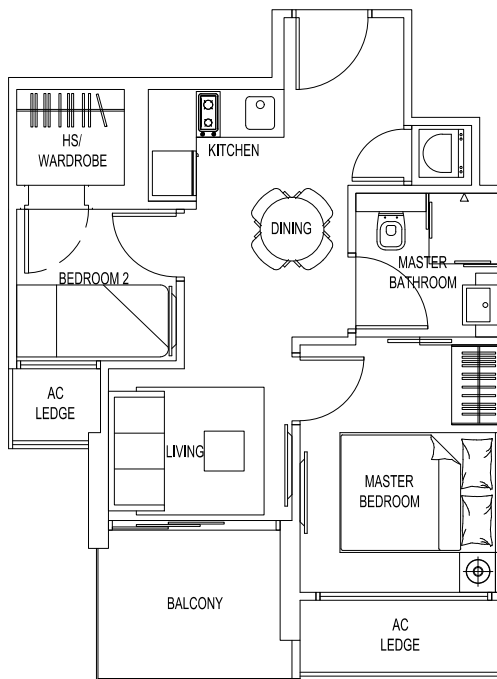
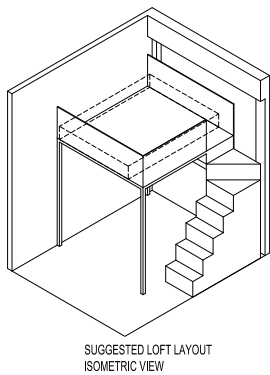
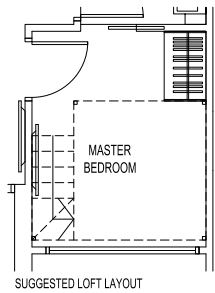

A1

AREA: 45.0 sqm

UNIT: #08-07, #09-07,
#10-07, #11-07, #12-07,
#13-07, #14-07, #15-07,
#16-07, #17-07, #18-07,
#19-07, #20-07, #21-07,
#22-07, #23-07, #24-07,
#25-07, #26-07

8TH TO 26TH STOREY

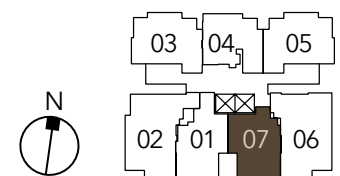

All floor area indicated are inclusive of aircon ledge, balcony, open balcony, roof terrace and private enclosed space (PES), where applicable. Areas are estimates only and subject to final survey. All floor plans are subject to changes as may be required or approved by the relevant authorities. Furniture shown are indicative only and are not provided. Please refer to the floor plans in the Sales & Purchase Agreement for details.



2-BEDROOM

A2-G

AREA: 56.0 sqm

UNIT: #07-01

7TH STOREY

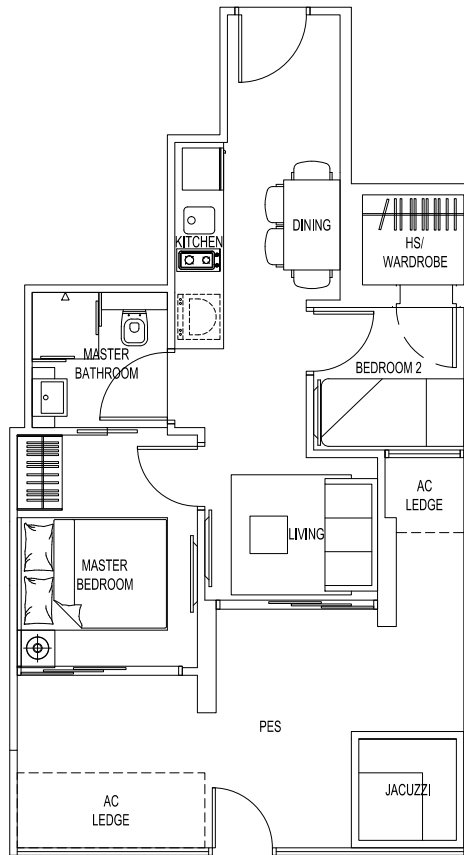

A2

AREA: 45.0 sqm

UNIT: #08-01, #09-01,
#10-01, #11-01, #12-01,
#13-01, #14-01, #15-01,
#16-01, #17-01, #18-01,
#19-01, #20-01, #21-01,
#22-01, #23-01, #24-01,
#25-01, #26-01

8TH TO 26TH STOREY

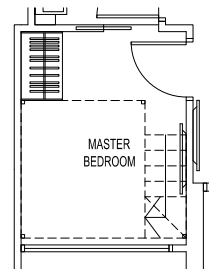
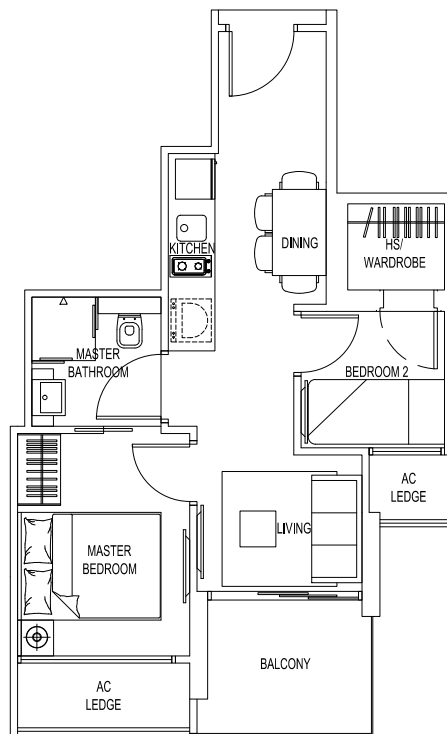

SUGGESTED LOFT LAYOUT

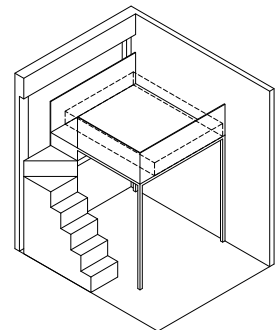

SUGGESTED LOFT LAYOUT ISOMETRIC VIEW

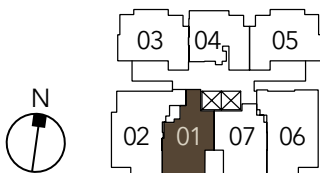

All floor area indicated are inclusive of aircon ledge, balcony, open balcony, roof terrace and private enclosed space (PES), where applicable. Areas are estimates only and subject to final survey. All floor plans are subject to changes as may be required or approved by the relevant authorities. Furniture shown are indicative only and are not provided. Please refer to the floor plans in the Sales & Purchase Agreement for details.

2-BEDROOM

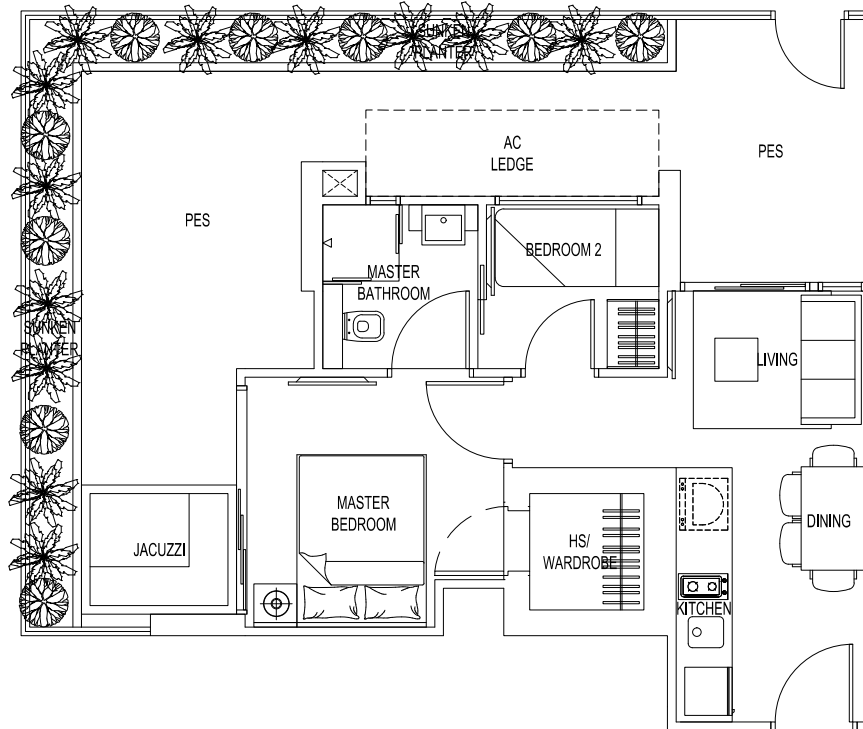

A3-G

AREA: 73.0 sqm

UNIT: #07-03

7TH STOREY

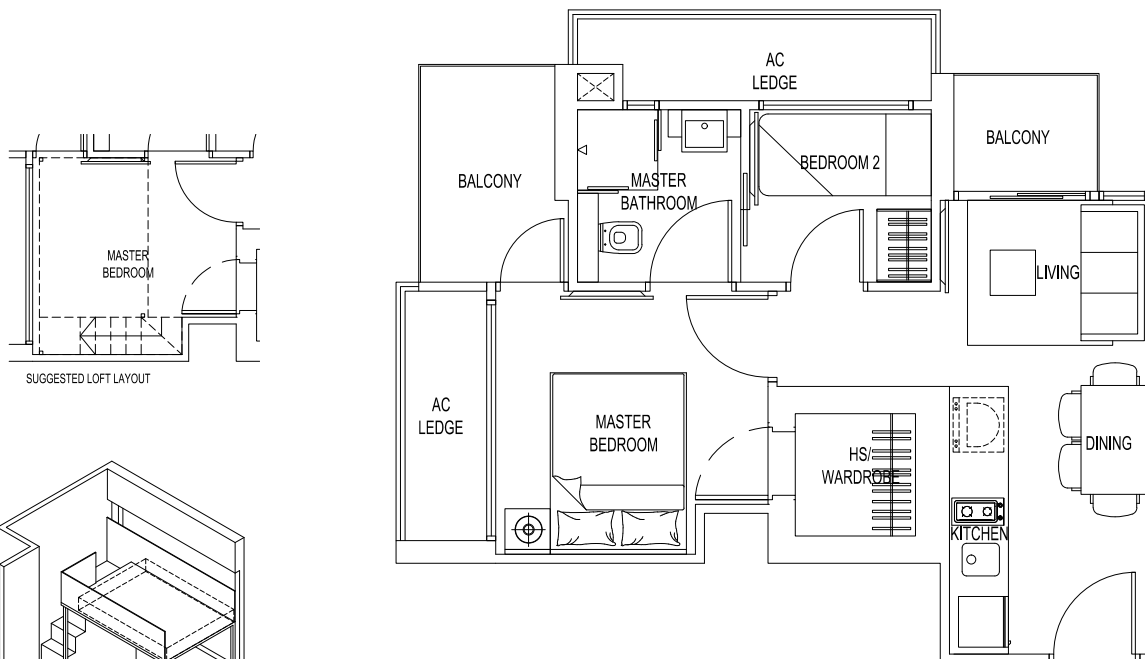

A3

AREA: 49.0 sqm

UNIT: #08-03, #09-03,
#10-03, #11-03, #12-03,
#13-03, #14-03, #15-03,
#16-03, #17-03, #18-03,
#19-03, #20-03, #21-03,
#22-03, #23-03, #24-03,
#25-03, #26-03, #27-03
8TH TO 27TH STOREY

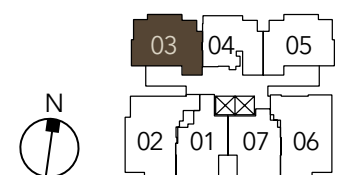
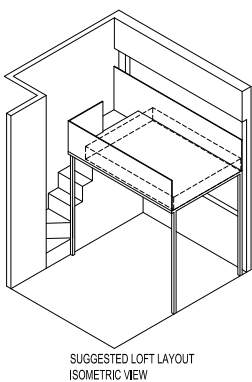
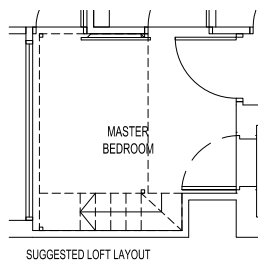

All floor area indicated are inclusive of aircon ledge, balcony, open balcony, roof terrace and private enclosed space (PES), where applicable. Areas are estimates only and subject to final survey. All floor plans are subject to changes as may be required or approved by the relevant authorities. Furniture shown are indicative only and are not provided. Please refer to the floor plans in the Sales & Purchase Agreement for details.



2-BEDROOM

A4-G

AREA: 53.0 sqm

UNIT: #07-04

7TH STOREY

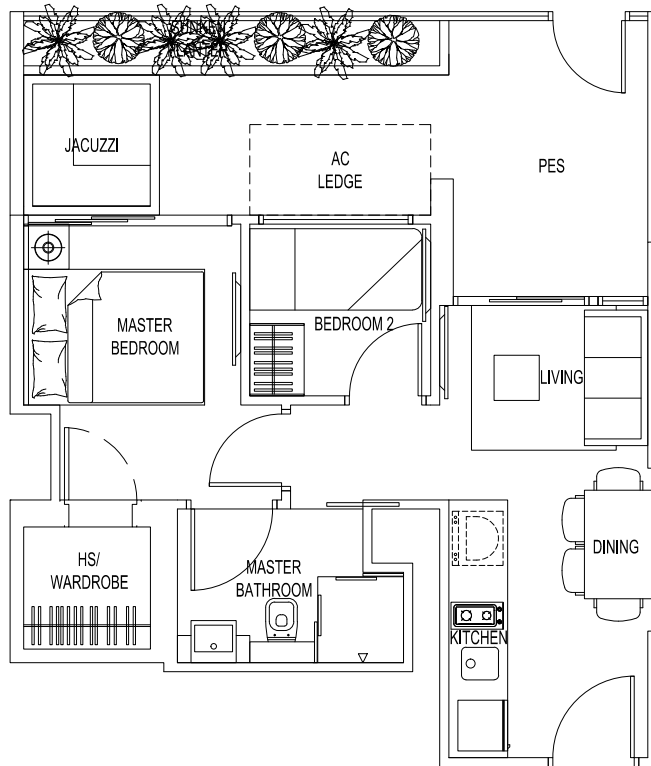

A4

AREA: 42.0 sqm

UNIT: #08-04, #09-04,
#10-04, #11-04, #12-04,
#13-04, #14-04, #15-04,
#16-04, #17-04, #18-04,
#19-04, #20-04, #21-04,
#22-04, #23-04, #24-04,
#25-04, #26-04, #27-04
8TH TO 27TH STOREY

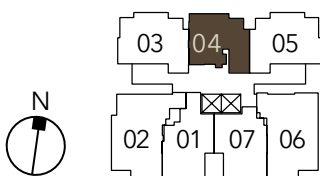
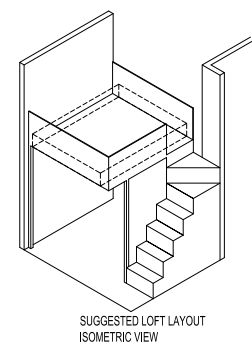
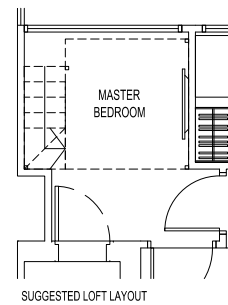
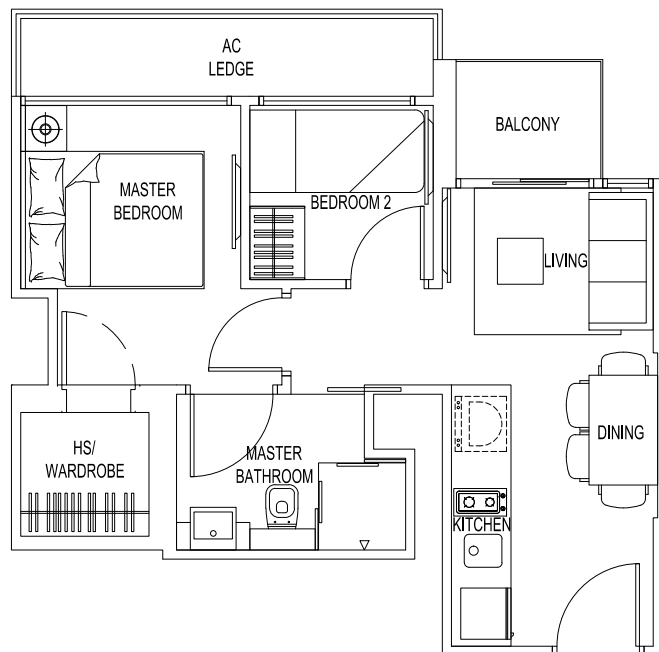

All floor area indicated are inclusive of aircon ledge, balcony, open balcony, roof terrace and private enclosed space (PES), where applicable. Areas are estimates only and subject to final survey. All floor plans are subject to changes as may be required or approved by the relevant authorities. Furniture shown are indicative only and are not provided. Please refer to the floor plans in the Sales & Purchase Agreement for details.

2-BEDROOM

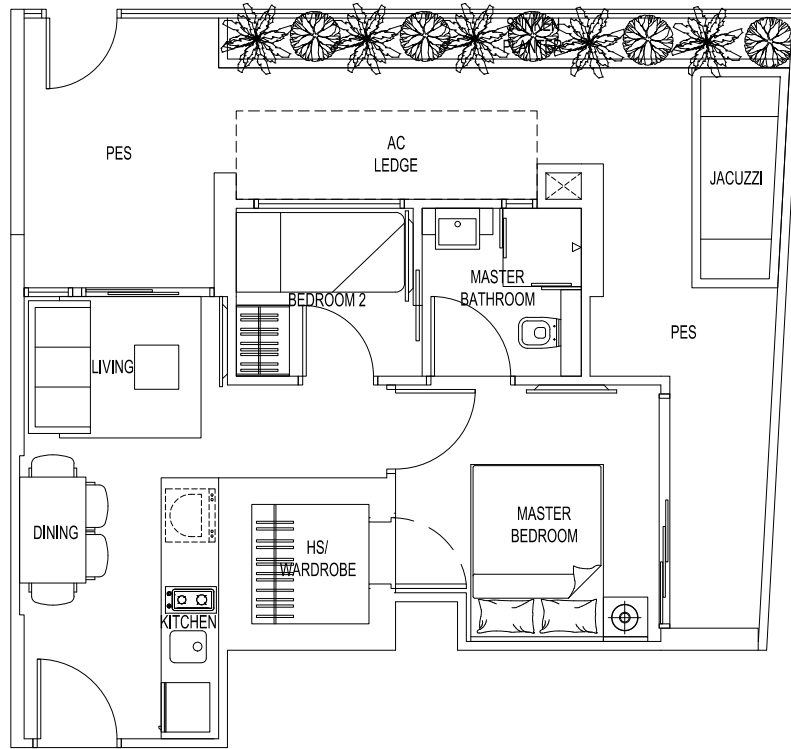

A5-G

AREA: 64.0 sqm

UNIT: #07-05

7TH STOREY

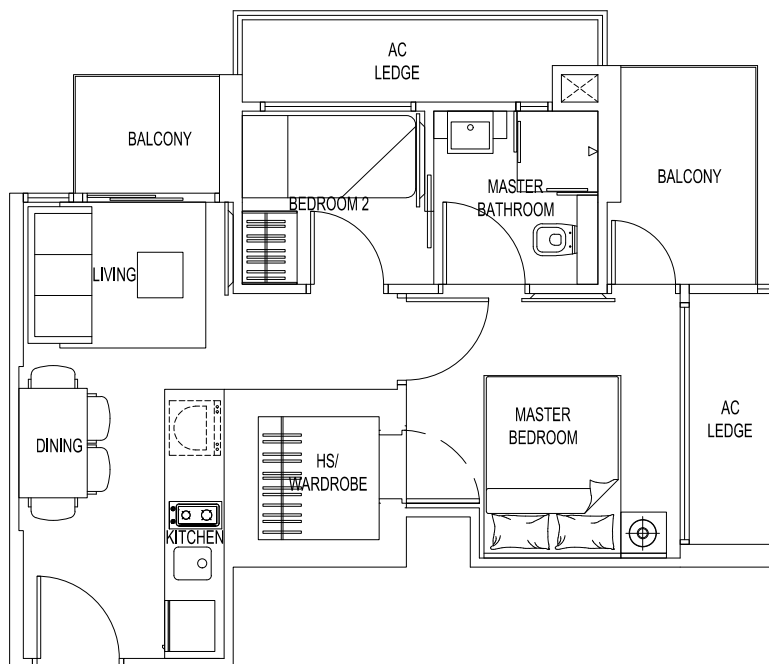

A5

AREA: 49.0 sqm

UNIT: #08-05, #09-05,
#10-05, #11-05, #12-05,
#13-05, #14-05, #15-05,
#16-05, #17-05, #18-05,
#19-05, #20-05, #21-05,
#22-05, #23-05, #24-05,
#25-05, #26-05, #27-05
8TH TO 27TH STOREY

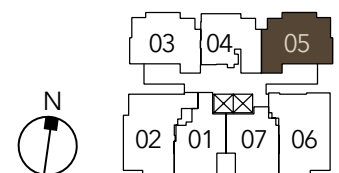
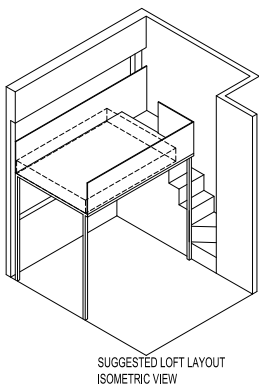
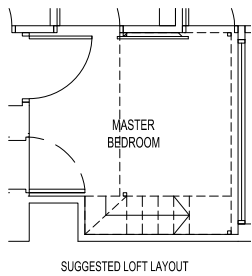

All floor area indicated are inclusive of aircon ledge, balcony, open balcony, roof terrace and private enclosed space (PES), where applicable. Areas are estimates only and subject to final survey. All floor plans are subject to changes as may be required or approved by the relevant authorities. Furniture shown are indicative only and are not provided. Please refer to the floor plans in the Sales & Purchase Agreement for details.



2-BEDROOM + 1 STUDY

B1-G

AREA: 83.0 sqm

UNIT: #07-06

7TH STOREY

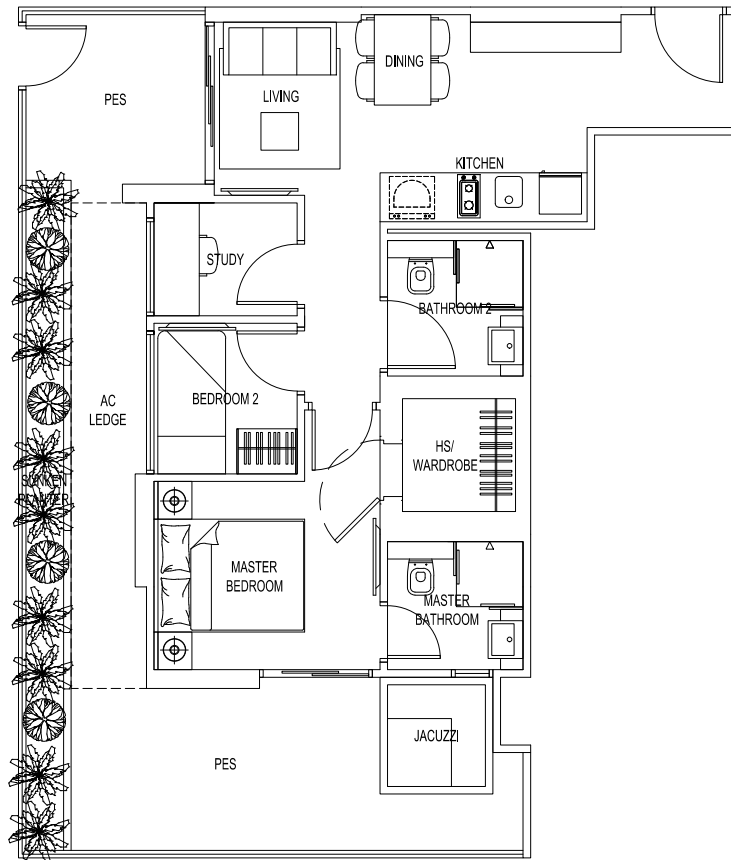

B1

AREA: 61.0 sqm

UNIT: #08-06, #09-06,
#10-06, #11-06, #12-06,
#13-06, #14-06, #15-06,
#16-06, #17-06, #18-06,
#19-06, #20-06, #21-06,
#22-06, #23-06, #24-06,
#25-06, #26-06, #27-06
8TH TO 27TH STOREY

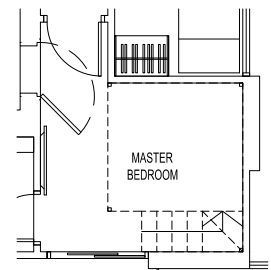
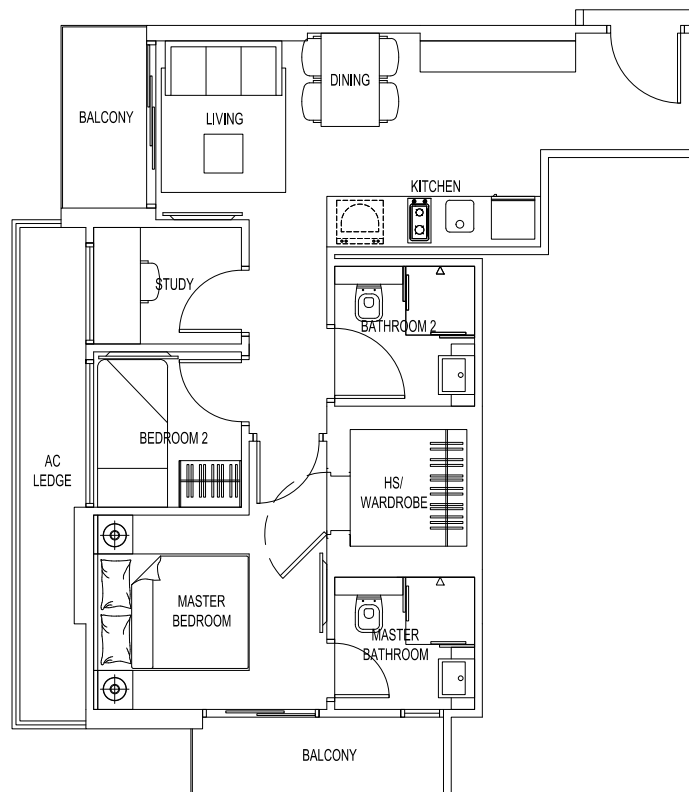

SUGGESTED LOFT LAYOUT

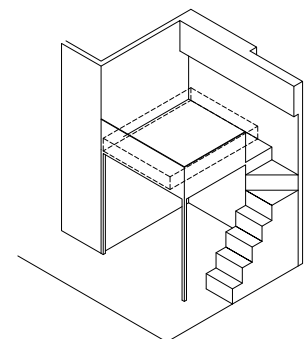

SUGGESTED LOFT LAYOUT ISOMETRIC VIEW

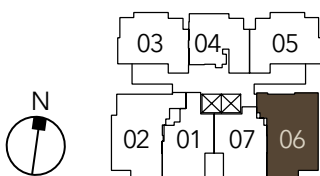

All floor area indicated are inclusive of aircon ledge, balcony, open balcony, roof terrace and private enclosed space (PES), where applicable. Areas are estimates only and subject to final survey. All floor plans are subject to changes as may be required or approved by the relevant authorities. Furniture shown are indicative only and are not provided. Please refer to the floor plans in the Sales & Purchase Agreement for details.

2 -BEDROOM + 1 STUDY

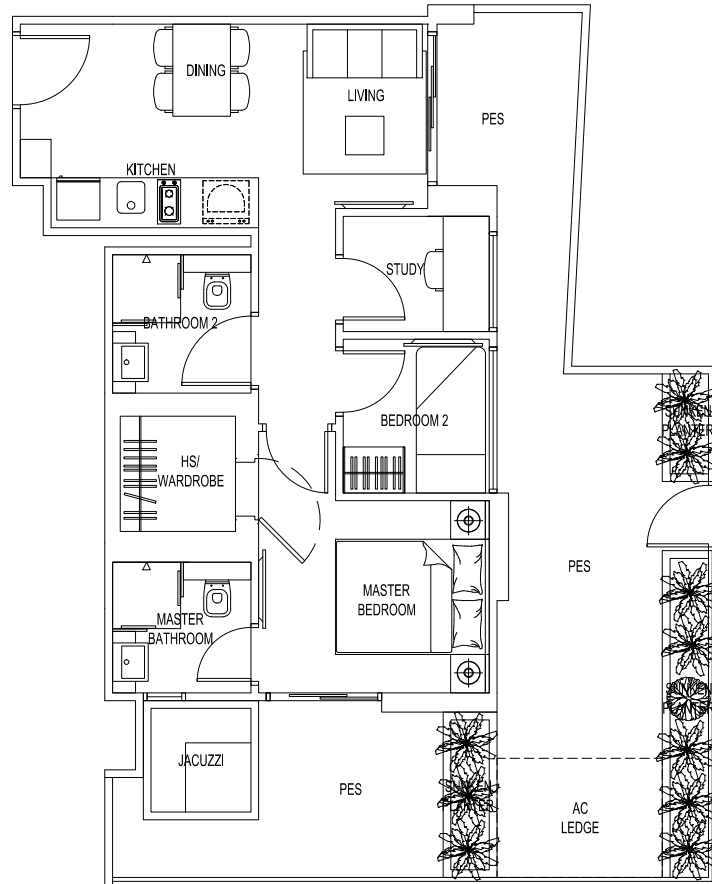

B2-G

AREA: 82.0 sqm

UNIT: #07-02

7TH STOREY

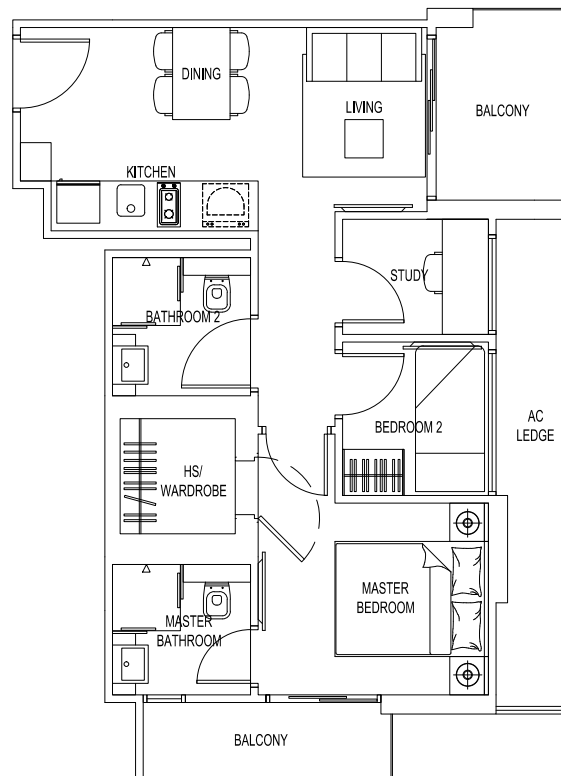

B2

AREA: 62.0 sqm

UNIT: #08-02, #09-02, #10-02, #11-02, #12-02, #13-02, #14-02, #15-02, #16-02, #17-02, #18-02, #19-02, #20-02, #21-02, #22-02, #23-02, #24-02, #25-02, #26-02, #27-02
8TH TO 27TH STOREY

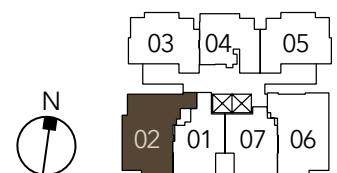
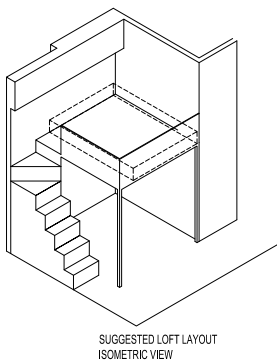
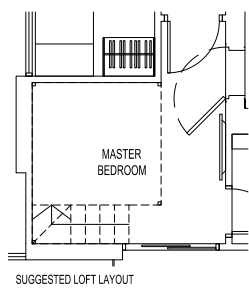

All floor area indicated are inclusive of aircon ledge, balcony, open balcony, roof terrace and private enclosed space (PES), where applicable. Areas are estimates only and subject to final survey. All floor plans are subject to changes as may be required or approved by the relevant authorities. Furniture shown are indicative only and are not provided. Please refer to the floor plans in the Sales & Purchase Agreement for details.



2-BEDROOM

A1-A

AREA: 47.0 sqm

UNIT: #27-07

27TH STOREY

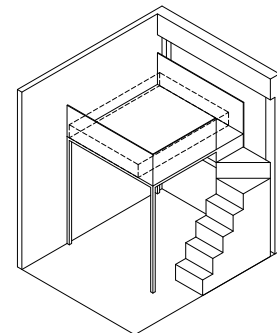
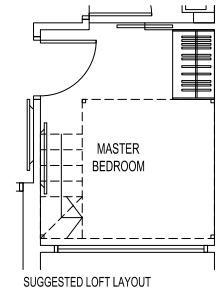
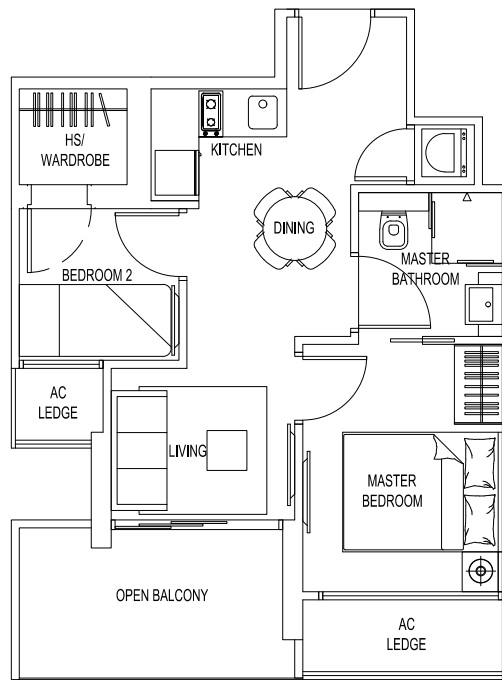
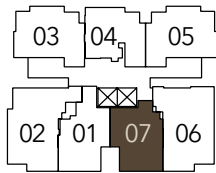

SUGGESTED LOFT LAYOUT ISOMETRIC VIEW

A2-A

AREA: 47.0 sqm

UNIT: #27-01

27TH STOREY

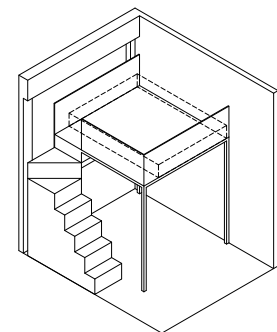
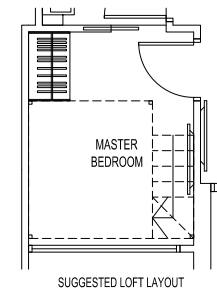
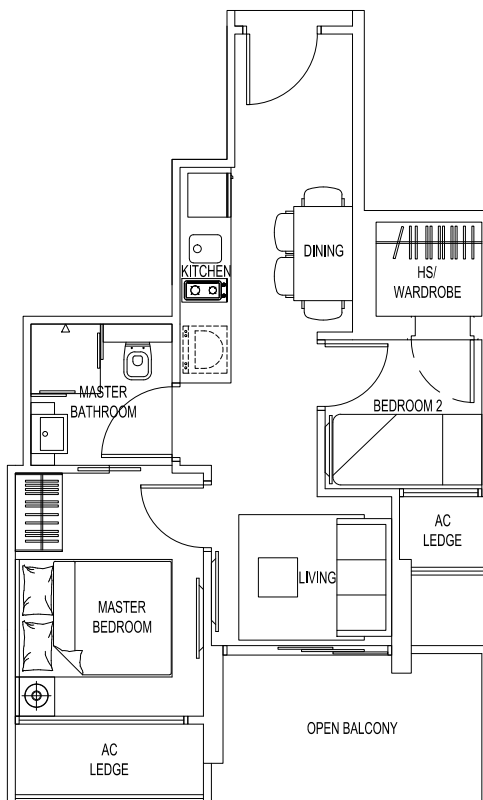
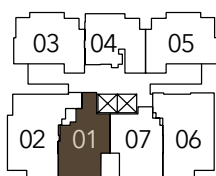

SUGGESTED LOFT LAYOUT ISOMETRIC VIEW



All floor area indicated are inclusive of aircon ledge, balcony, open balcony, roof terrace and private enclosed space (PES), where applicable. Areas are estimates only and subject to final survey. All floor plans are subject to changes as may be required or approved by the relevant authorities. Furniture shown are indicative only and are not provided. Please refer to the floor plans in the Sales & Purchase Agreement for details.

PENTHOUSE

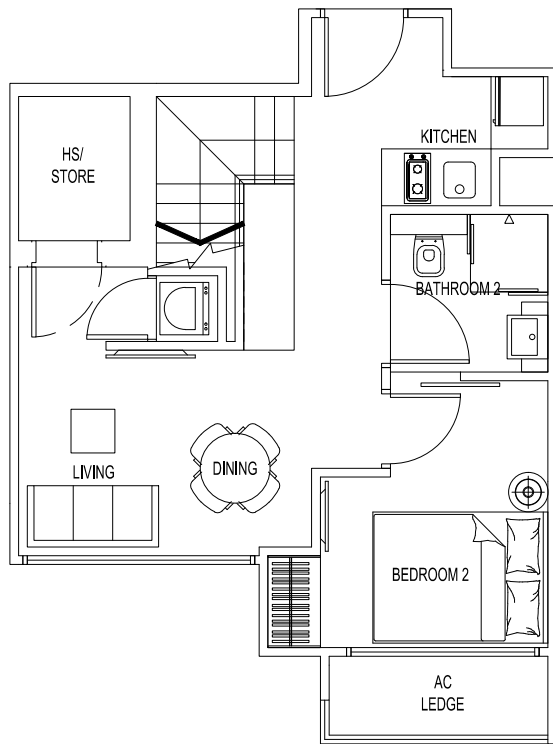

A1-P

AREA: 75.0 sqm

UNIT: #28-07

28TH-29TH STOREY

LOWER PENTHOUSE UNIT

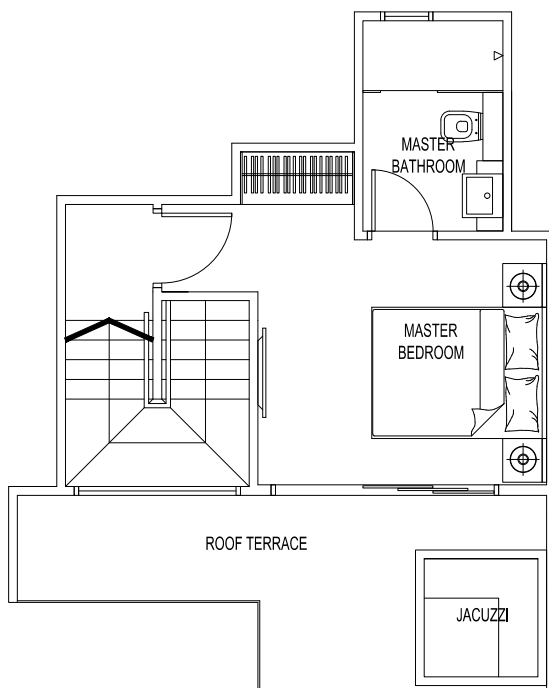

A1-UP

UPPER PENTHOUSE UNIT

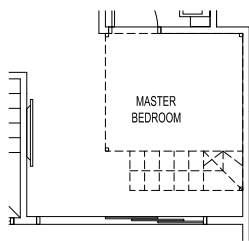

SUGGESTED LOFT LAYOUT

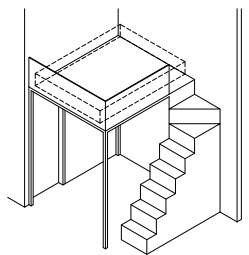

SUGGESTED LOFT LAYOUT ISOMETRIC VIEW

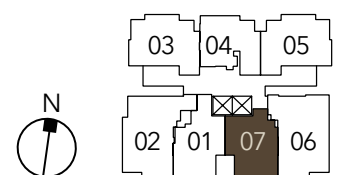

All floor area indicated are inclusive of aircon ledge, balcony, open balcony, roof terrace and private enclosed space (PES), where applicable. Areas are estimates only and subject to final survey. All floor plans are subject to changes as may be required or approved by the relevant authorities. Furniture shown are indicative only and are not provided. Please refer to the floor plans in the Sales & Purchase Agreement for details.



PENTHOUSE

A2-P

AREA: 74.0 sqm

UNIT: #28-01

28TH-29TH STOREY

LOWER PENTHOUSE UNIT

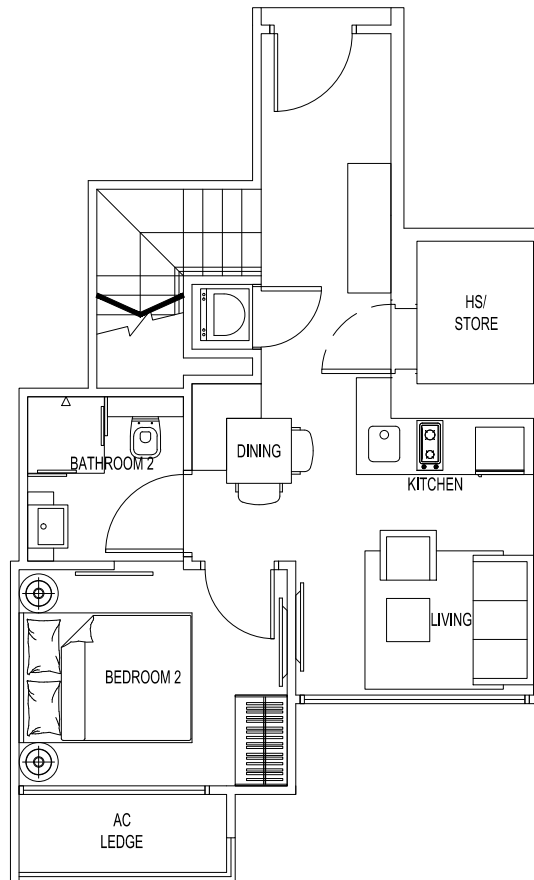

A2-UP

UPPER PENTHOUSE UNIT

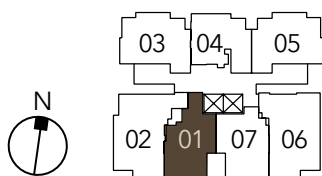
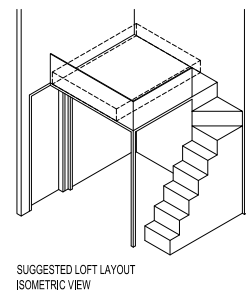
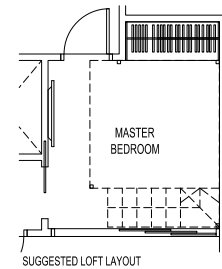
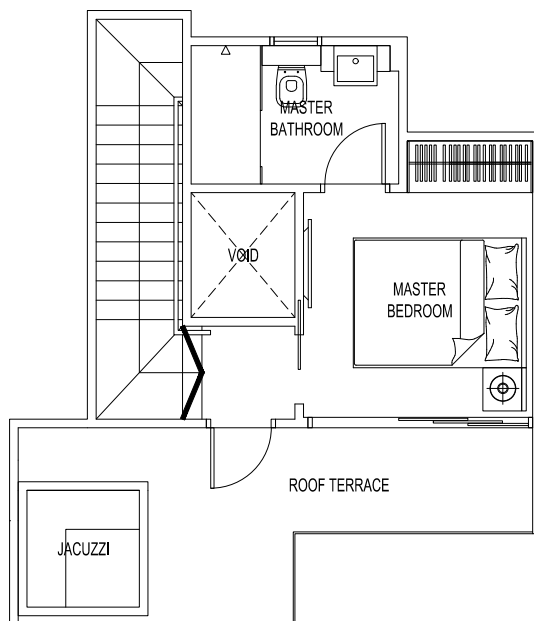

All floor area indicated are inclusive of aircon ledge, balcony, open balcony, roof terrace and private enclosed space (PES), where applicable. Areas are estimates only and subject to final survey. All floor plans are subject to changes as may be required or approved by the relevant authorities. Furniture shown are indicative only and are not provided. Please refer to the floor plans in the Sales & Purchase Agreement for details.

PENTHOUSE

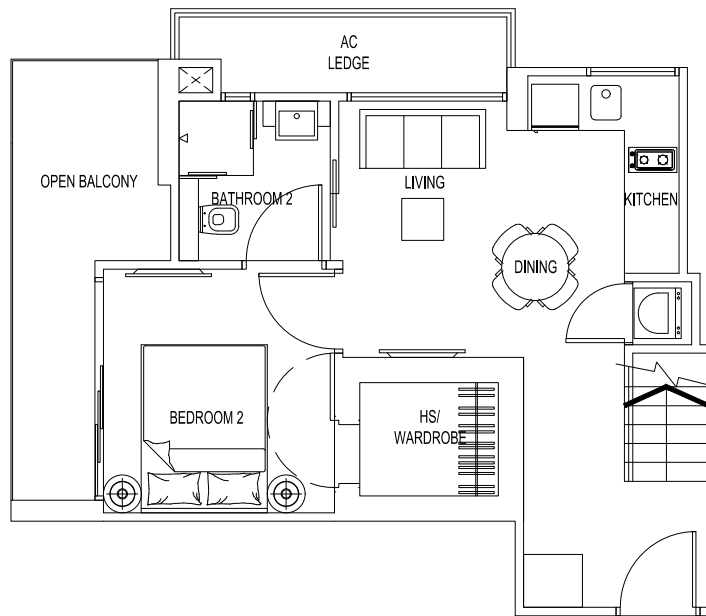

A3-P

AREA: 88.0 sqm

UNIT: #28-03

28TH-29TH STOREY

LOWER PENTHOUSE UNIT

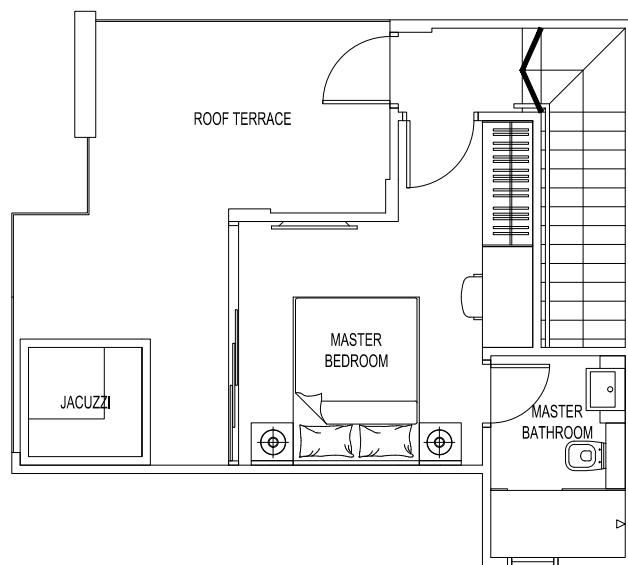

A3-UP

UPPER PENTHOUSE UNIT

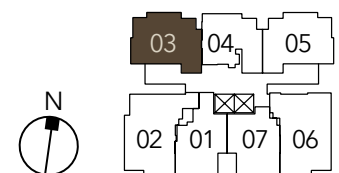
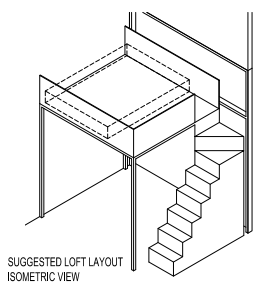
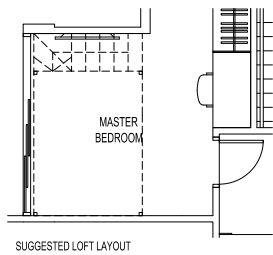

All floor area indicated are inclusive of aircon ledge, balcony, open balcony, roof terrace and private enclosed space (PES), where applicable. Areas are estimates only and subject to final survey. All floor plans are subject to changes as may be required or approved by the relevant authorities. Furniture shown are indicative only and are not provided. Please refer to the floor plans in the Sales & Purchase Agreement for details.



PENTHOUSE

A4-P

AREA: 84.0 sqm

UNIT: #28-04

28TH-29TH STOREY

LOWER PENTHOUSE UNIT

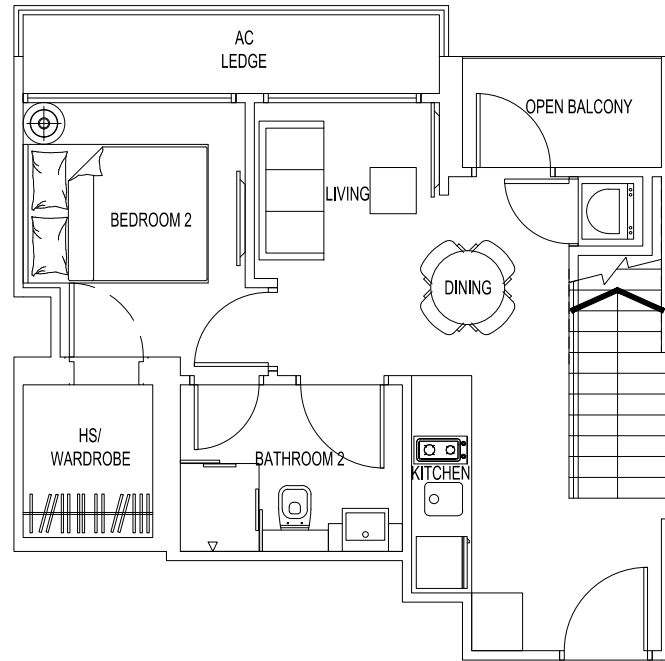

A4-UP

UPPER PENTHOUSE UNIT

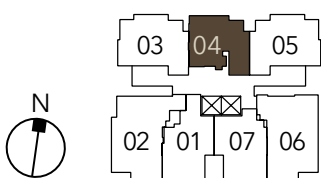
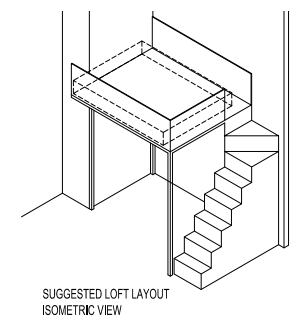
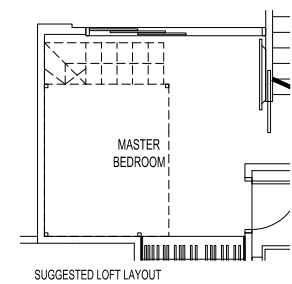
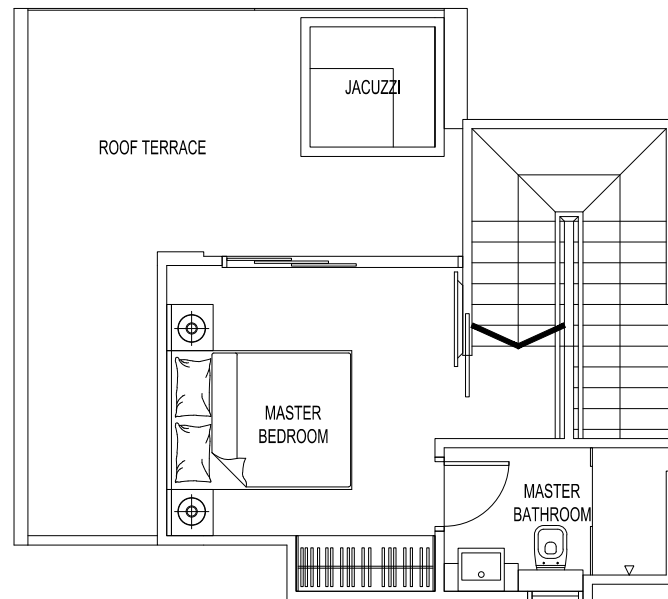

All floor area indicated are inclusive of aircon ledge, balcony, open balcony, roof terrace and private enclosed space (PES), where applicable. Areas are estimates only and subject to final survey. All floor plans are subject to changes as may be required or approved by the relevant authorities. Furniture shown are indicative only and are not provided. Please refer to the floor plans in the Sales & Purchase Agreement for details.

PENTHOUSE

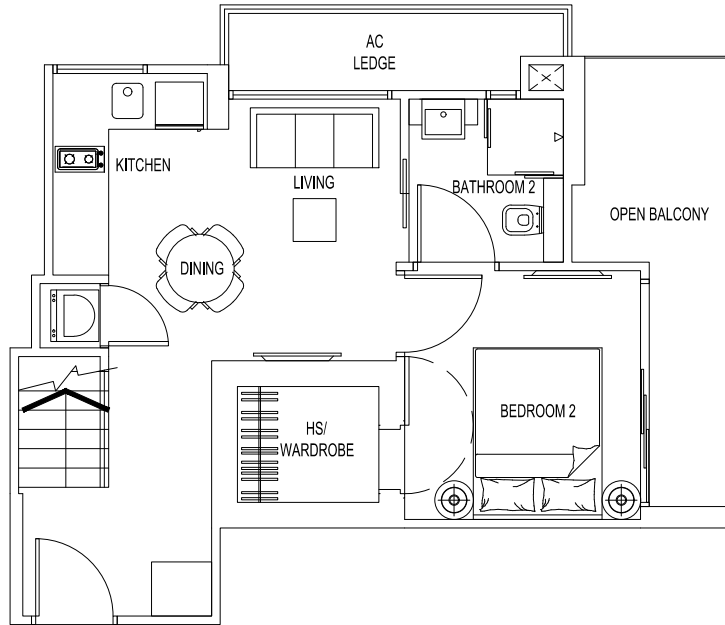

A5-P

AREA: 91.0 sqm

UNIT: #28-05

28TH-29TH STOREY

LOWER PENTHOUSE UNIT

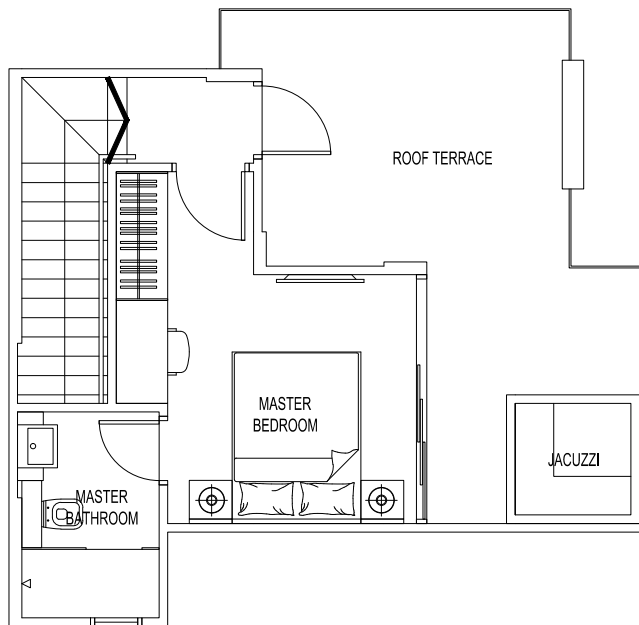

A5-UP

UPPER PENTHOUSE UNIT

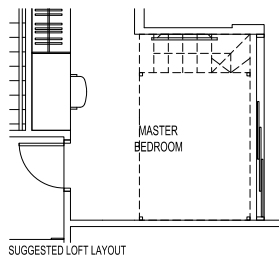

SUGGESTED LOFT LAYOUT

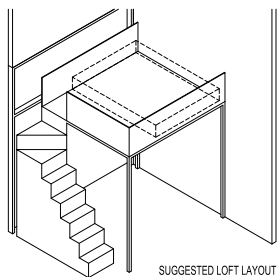

SUGGESTED LOFT LAYOUT ISOMETRIC VIEW

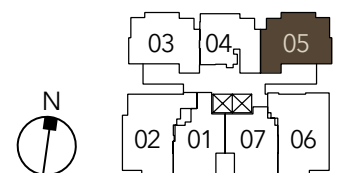

All floor area indicated are inclusive of aircon ledge, balcony, open balcony, roof terrace and private enclosed space (PES), where applicable. Areas are estimates only and subject to final survey. All floor plans are subject to changes as may be required or approved by the relevant authorities. Furniture shown are indicative only and are not provided. Please refer to the floor plans in the Sales & Purchase Agreement for details.



PENTHOUSE

B1-P

AREA: 101.0 sqm

UNIT: #28-06

28TH-29TH STOREY

LOWER PENTHOUSE UNIT

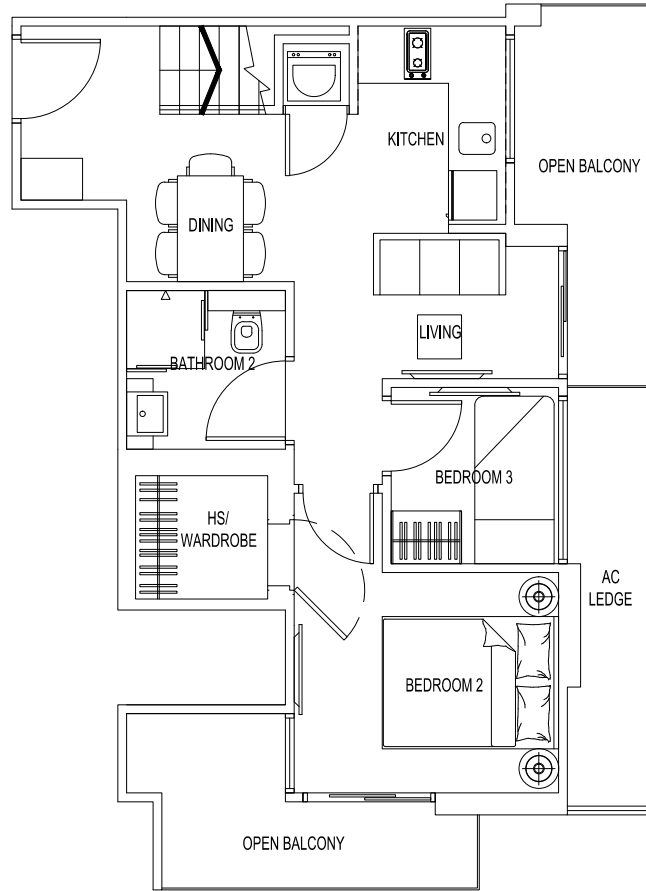

B1-UP

UPPER PENTHOUSE UNIT

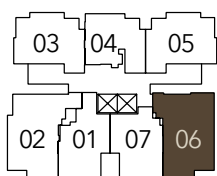
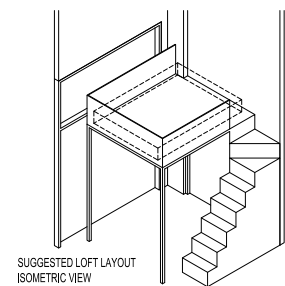
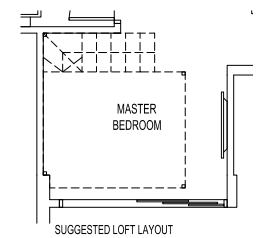
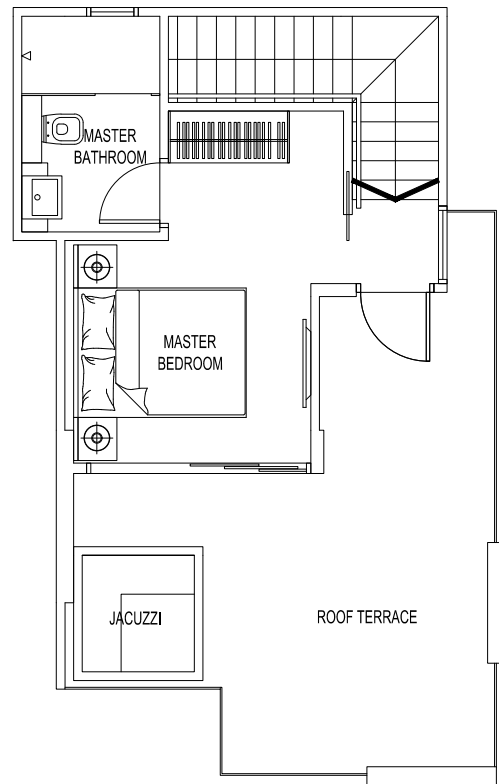

All floor area indicated are inclusive of aircon ledge, balcony, open balcony, roof terrace and private enclosed space (PES), where applicable. Areas are estimates only and subject to final survey. All floor plans are subject to changes as may be required or approved by the relevant authorities. Furniture shown are indicative only and are not provided. Please refer to the floor plans in the Sales & Purchase Agreement for details.

PENTHOUSE

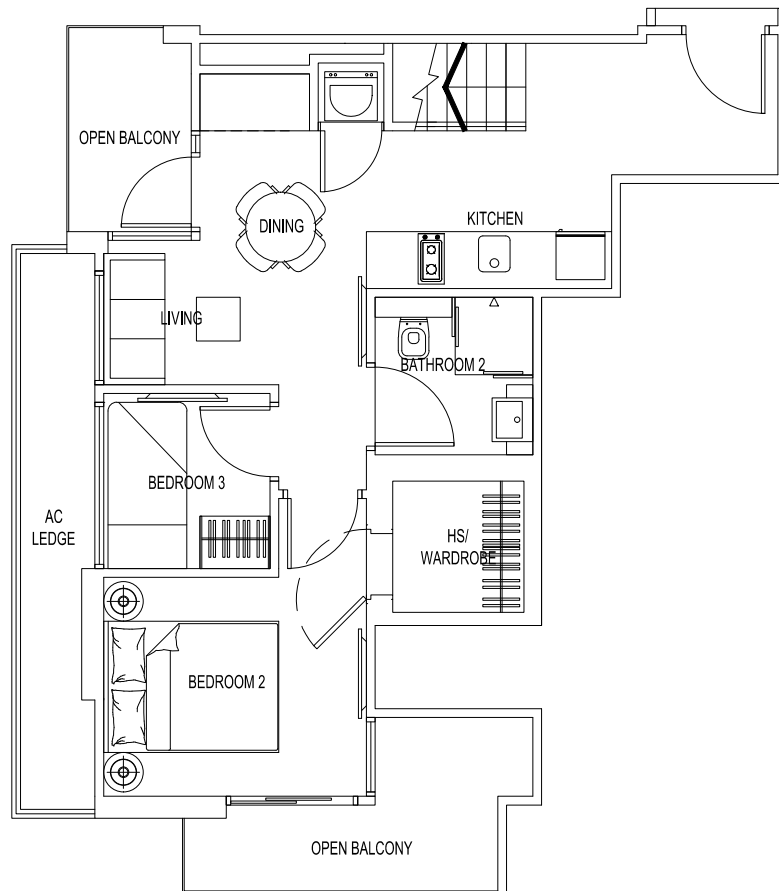

B2-P

AREA: 102.0 sqm

UNIT: #28-02

28TH-29TH STOREY

LOWER PENTHOUSE UNIT

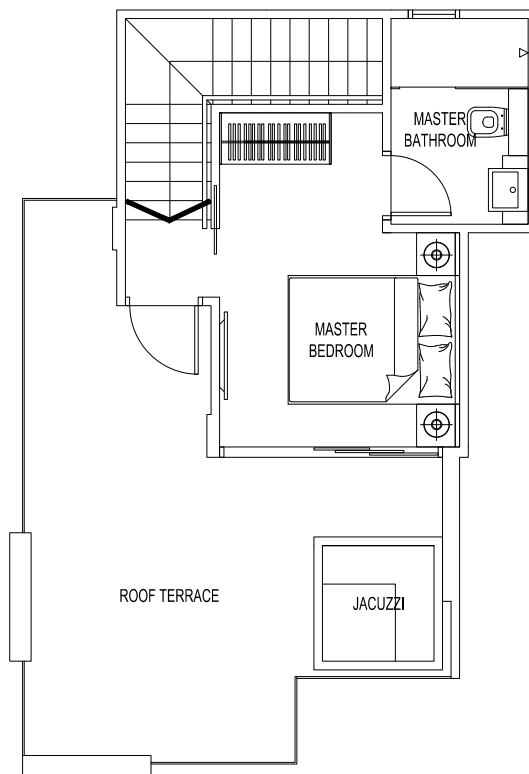

B2-UP

UPPER PENTHOUSE UNIT

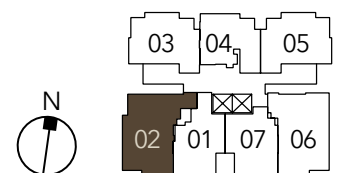
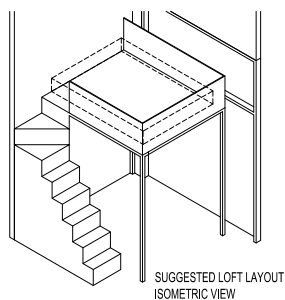
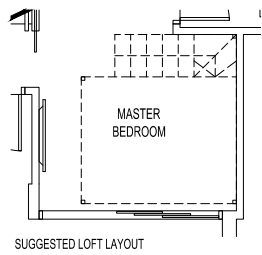

All floor area indicated are inclusive of aircon ledge, balcony, open balcony, roof terrace and private enclosed space (PES), where applicable. Areas are estimates only and subject to final survey. All floor plans are subject to changes as may be required or approved by the relevant authorities. Furniture shown are indicative only and are not provided. Please refer to the floor plans in the Sales & Purchase Agreement for details.



Developer:



Marketing Agents:



• Developer: LVND Homes Pte. Ltd. (Registration No. XXXXXXXXW) • Developer's Licence No.: CXXXXXX • Tenure of Land: Freehold • Lot No.: Lot (S) 2267T & 2269K (SL) PT MK17 at Jalan Dusun • Approved BP No.: A1217-00346-2011-BP01 dated 25 Jul 2012 • Date of Notice of Vacant Possession under the S&P Agreement: No later than XX XX 201X • Expected date of legal completion: No later than XX XX 201X or 3 years after the date of delivery of vacant possession, whichever is earlier.

Disclaimer & Additional Notes

While every reasonable care has been taken in preparation of this brochure, the developer and its agent cannot be held responsible for the inaccuracies or omissions. All statements are believed to be correct but shall not be regarded as statements or representation of fact. All information and specifications, renderings, visual representations, and plans are current at the time of publication and are subject to change as may be required by us and/or the competent authorities.

The brand, colour and model of all materials, fittings, equipment, finishes, installations and appliances supplied shall be provided subject to Architect's selection, market availability and the sole discretion of the Vendor.

All information, specifications and statements herein shall not be treated to form part of an offer or contract. Floor plans are subject to amendments as may be required by the relevant authorities. Visual representations, model, showflat displays and illustrations, photographs, art renderings and other graphic representations and references, not limited to landscape and furniture, are intended to portray only artistic impressions of the development and cannot be regarded as representations of fact. Floor areas are only approximate measurements and subject to final survey.

The Sales & Purchase Agreement shall form the entire agreement between the developer and purchaser and shall supersede all statements, representations or promise made prior to the signing of the Sales & Purchase Agreement and shall in no way modified by any statements, representations or promise made by the developer or the Marketing agents.